

**Quick Ship**

- Same day shipment on all stock heaters with post terminals or Type B leads.

**Band Heaters****MI Barrel and Nozzle**

The MI band is a high performance heater. Its performance and name are derived from Watlow's exclusive mineral insulation—a material that has much higher thermal conductivity than the mica and hard ceramic insulators used in conventional heaters.

A thin layer of the “high” thermal conductive MI material is used to electrically insulate the element wire from the inside diameter of the heater sheath. A thicker, “low” thermal conductivity layer backs up the element wire, directing the heat inward toward the part that is being heated. The result is more efficient heat transfer—a performance solution that lowers element wire temperatures and increases heater life.

**Performance Capabilities**

- Heater operating temperatures to 760°C (1400°F)
- Watt densities to 230 W/in<sup>2</sup> (35.6 W/cm<sup>2</sup>) available on small diameter nozzle bands
- Watt densities to 100 W/in<sup>2</sup> (15.5 W/cm<sup>2</sup>) available on large diameter barrel bands

**Features and Benefits****Operating temperatures to 760°C (1400°F)**

- Safely melts resins such as Peek®, Teflon®, Ultem® and Zytel®

**Higher watt densities**

- Contributes faster heat-up and through-put for increased productivity

**High thermal conductivity of MI and low mass construction**

- Gives an almost instant response to temperature control
- Eliminates thermal lag and temperature overshoot associated with ceramic knuckle heaters

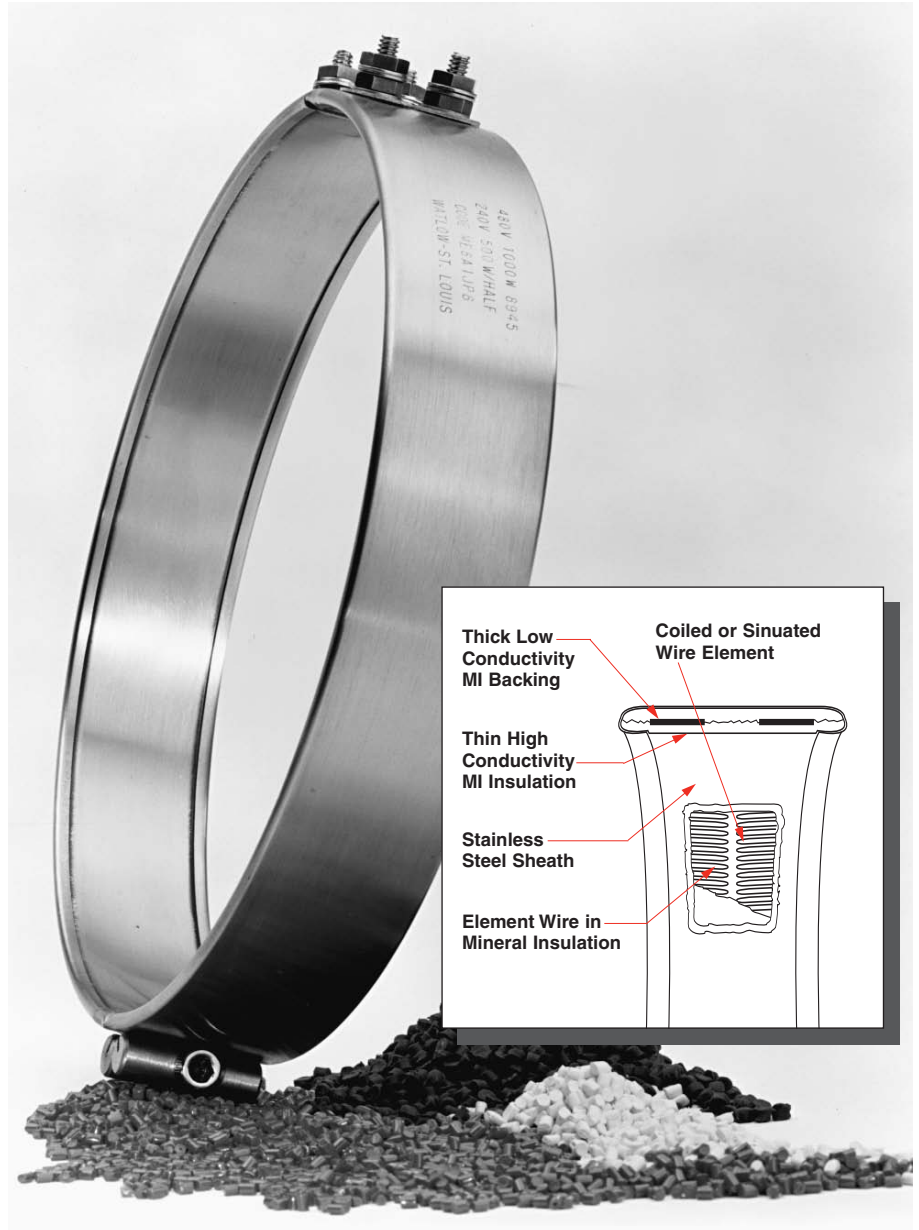
**Stainless steel cover and side fold design**

- Resists contamination by overflow of plastic or other free-flowing materials
- Side folds turn to the inside diameter rather than the outside diameter

**Permanently attached clamp bars**

- Eliminates cumbersome clamping straps, which make installation easier

**Applications**

- Extruders
- Blown film dies
- Injection molding machines
- Other cylinder heating applications

Teflon® and Zytel® are registered trademarks of E.I. du Pont de Nemours & Company.

Ultem® is a registered trademark of General Electric Corporation.

Peek® is a registered trademark of Greene, Tweed & Company.

# Band Heaters

## MI Barrel and Nozzle

### Applications and Technical Data

The *Physical Limitations of Variations* table shows you the availability of widths, inside diameters and terminations for Watlow's MI band heaters. To make sure the available terminations will meet your application needs, refer

to the illustrations of termination variations in this section.

If you need to exceed limitations shown, contact your Watlow sales engineer or authorized distributor.

### Physical Limitations of Variations

Widths in. (mm)	I.D. Available—in. (mm)						Available Terminations
	1 pc. Construction		Expandable		2 pc. Construction		
	Minimum in. (mm)	Maximum in. (mm)	Minimum in. (mm)	Maximum in. (mm)	Minimum in. (mm)	Maximum in. (mm)	
1 (25.4)	1 (25.4)	14 (355.6)	3 (76.2)	14 (355.6)	3 (76.2)	14 (255.6)	All
1½ (34.9)	1 (25.4)	3 (76.2)	3 (76.2)	6 (152.4)	3 (76.2)	6 (152.4)	All
1½ (38.1)	1 (25.4)	14 (355.6)	3 (76.2)	14 (355.6)	3 (76.2)	28 (711.2)	All
2 (50.8)	1½ (31.8)	14 (355.6)	3 (76.2)	14 (355.6)	3 (76.2)	28 (711.2)	All
2½ (63.5)	1½ (31.8)	14 (355.6)	3 (76.2)	14 (355.6)	3 (76.2)	28 (711.2)	All
3 (76.2)	1½ (31.8)	14 (355.6)	3 (76.2)	14 (355.6)	3 (76.2)	28 (711.2)	All
3½ (88.9)	1½ (44.5)	14 (355.6)	3 (76.2)	14 (355.6)	3 (76.2)	28 (711.2)	All - Except 90° "B" Leads
4 (101.6)	2 (50.8)	14 (355.6)	3 (76.2)	14 (355.6)	3 (76.2)	28 (711.2)	All
4½ (114.3)	2½ (57.2)	14 (355.6)	3 (76.2)	14 (355.6)	3 (76.2)	28 (711.2)	All
5 (127.0)	2½ (63.5)	14 (355.6)	3 (76.2)	14 (355.6)	4 (101.6)	28 (711.2)	All - Except 90° "B" Leads
5½ (139.7)	2¾ (69.85)	14 (355.6)	3 (76.2)	14 (355.6)	4 (101.6)	28 (711.2)	Post Terminals, SLE
6 (152.4)	3 (76.2)	14 (355.6)	3 (76.2)	14 (355.6)	4 (101.6)	28 (711.2)	All
7 (177.8)	N/A	N/A	4 (101.6)	14 (355.6)	N/A	N/A	Post Terminals, SLE

#### General Limitations:

- Maximum width of 1 inch (25 mm) diameter heater is 1.5 inches wide (38 mm).
- Maximum heater width = 2x heater diameter
- Minimum I.D. for Type B, C, E and H leads = 1 inch (25 mm)
- Minimum I.D. for Type B—90 degree leads = 1½ inches (28 mm)
- Maximum lead amps: 12.5A per pair
- Maximum amps (post terminals): 30A per pair
- Minimum diameter and width for SLE is 4 inches x 1½ inch width
- SLE maximum 17.0 amps
- 90 degree bends not available over 250V~(ac)

#### Standard Gaps:

- ≤ 3 inches = ⅛ inch nominal
- 3 inches ≤ 6 inches = ¼ inch nominal ±⅛ inch
- 6 inches ≤ 14 inches = ⅜ inch nominal ±⅛ inch
- > 14 inches = ½ inch nominal ±¼ inch

# Band Heaters

## MI Barrel and Nozzle

### Applications and Technical Data

#### Calculating Watt Density

Watt density is the amount of wattage per square inch of heated area. To determine watt density, divide the total wattage by the heated area.

$$\text{Watt Density} = \frac{\text{Total Watts}}{\text{Heated Area}}$$

To apply this equation, we must define the term "heated area."

Heated area is the total contact surface of the heater less areas of no-heat that are found around terminals, mounting holes, etc.

$$\text{Heated Area} = \text{Total Contact Area} - \text{No-Heat Area}$$

To calculate the heated area:

1. Locate the **no-heat factor** from the chart below that corresponds

Type	Factor in.
1 pc. lead unit Type B, C, H, E or 90°B	1.37
1 pc. post terminal	1.60
1 pc. expandable post term	3.18
1 pc. expandable lead unit	3.00
True 2 pc. post term	3.20
True 2 pc. leads	2.74
SLE	3.68

to the type of heater being considered.

2. To use the formula below, insert the no-heat factors, diameter and width (in inches).

$$\text{Heated Area} = (3.14 \times \text{Diameter} - \text{No-Heat Factor}) \times \text{Width}$$

#### Maximum Allowable Watt Density

The following derating factors apply to the *Maximum Allowable Watt Density* chart, which are shown in both inch base and metric for your convenience. Please review these factors and the chart to determine the correct watt density curve for your application.

#### Derating Factors:

- For units over two inches (51 mm) in width, multiply watt density by 0.80.
- In applications where unusual operating conditions are present, such as irregular mounting surfaces, contact the Watlow factory in St. Louis, Missouri, for watt density limitations.
- For two-piece units used in vertical applications, refer to *Clamping Matrix Application Guide*.
- For applications where insulating blankets are used, multiply W/in<sup>2</sup> (W/cm<sup>2</sup>) by 0.75.

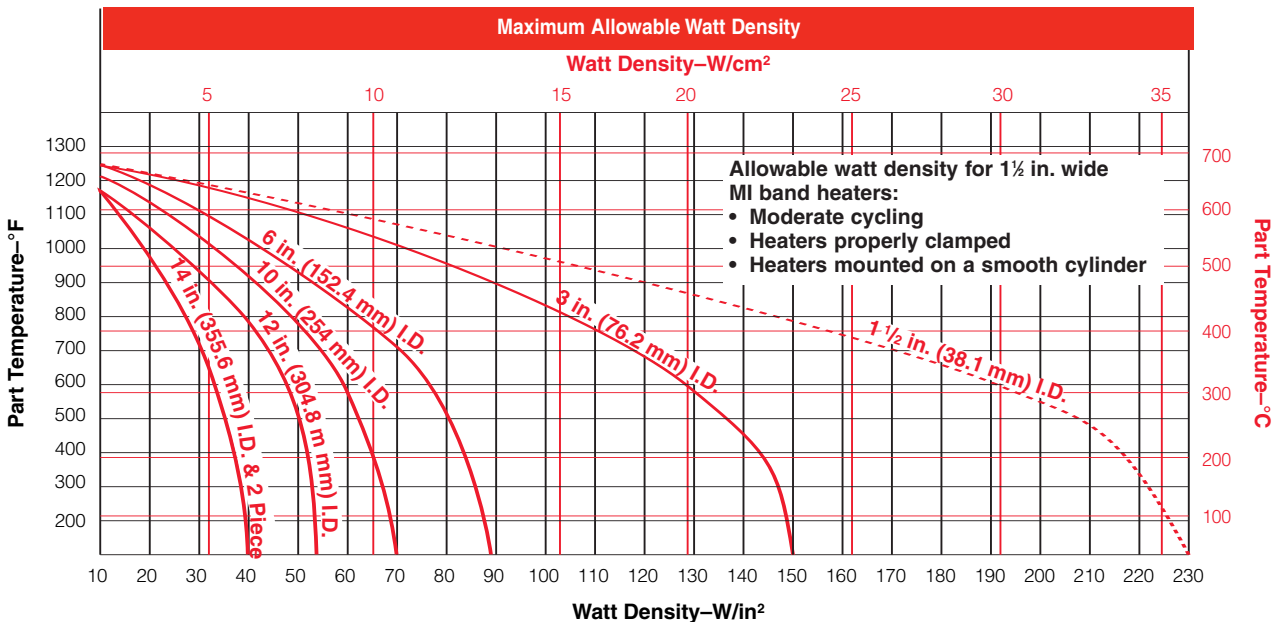

# Band Heaters

## MI Barrel and Nozzle

### Applications and Technical Data

- Review the *Watt Density* chart to ensure the application does not exceed the maximum watt density at operating temperature after applying derating factors.
- Locate clamping guideline for unit diameter, width and watt density.
- Description of guideline letters are at the bottom of the *MI Band Clamping Matrix Application Guide*.
- **Note:** Upward arrows are up to and not including specified watt density. Downward arrows are greater than or equal to specified watt density.

MI Band Clamping Matrix Application Guide

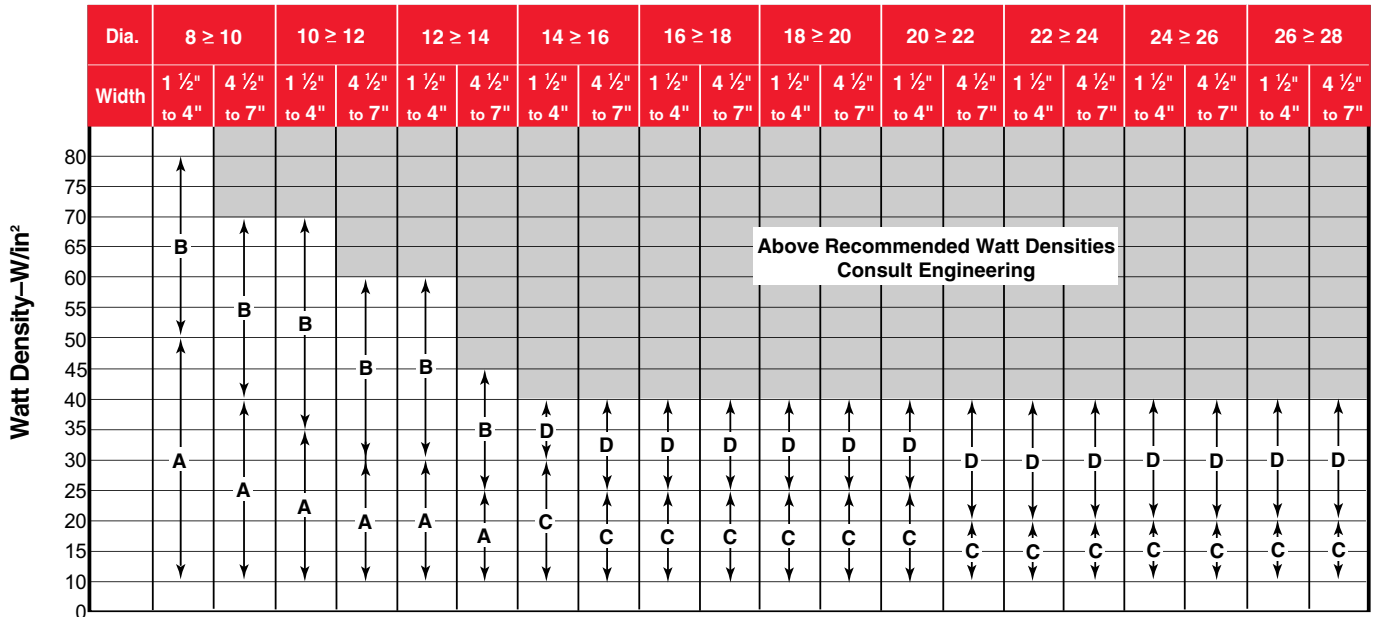

- A = Standard clamping, expandable or one piece construction
  - B = Spring clamps, expandable or one piece construction
  - C = Spring clamps, at one gap, welded barrel nuts at other gap
  - D = Spring clamps, spring clamps at both gaps
- | Width             | Clamp Points at Each Gap |
|-------------------|--------------------------|
| ≥ 5 in. (127 mm)  | 3                        |
| ≥ 3 in. (76.2 mm) | 2                        |
| < 3 in. (76.2 mm) | 1                        |

**Note:** One inch wide heaters use welded barrel nuts rather than clamp bars.

# Band Heaters

## MI Barrel and Nozzle Termination Variations

Leads Type B, Type B—90 degree Rotation, Type B—180 degree Rotation or Type C: Two fiberglass-insulated lead wires exit in a single metal braid for good abrasion protection, lead flexibility and wiring convenience. Leads are two inches (51 mm) longer than braid. Shipped with 12 inch (305 mm) leads, unless longer length is specified. To order, specify **type** and **length**.

### Sealed Lead Option

**Non-Stock**

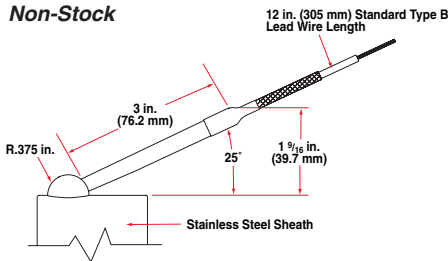

### Type B

**Stock**

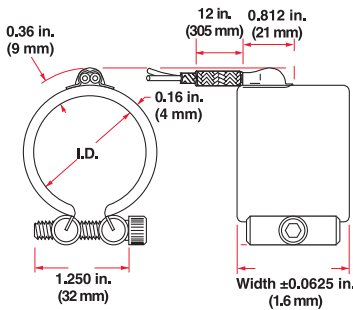

### Type B—180 Degree Rotation

**Stock**

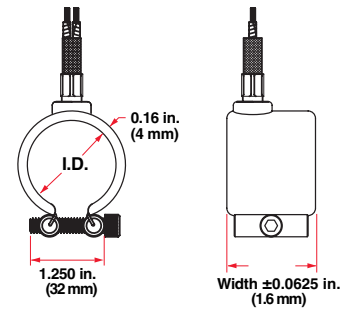

### Type B—90 Degree Rotation

**Non-Stock**

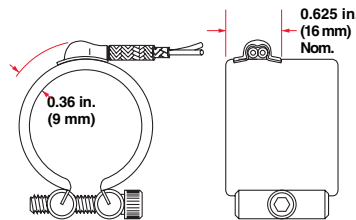

### Type C

**Stock**

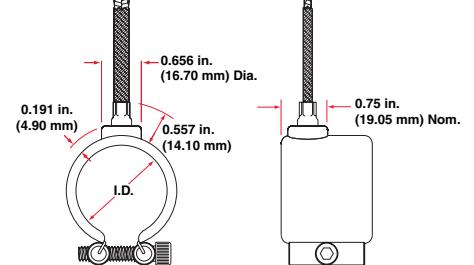

## Post Terminals

**Stock**

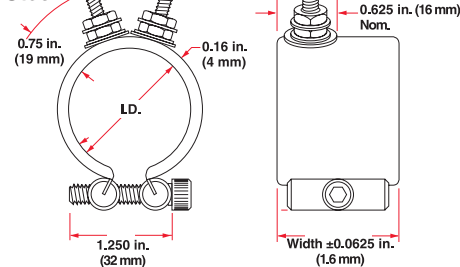

Post terminals provide optimum connections. Screw thread is 10-24. To order, specify **post terminals** (metric threads available).

### Type K

**Stock**

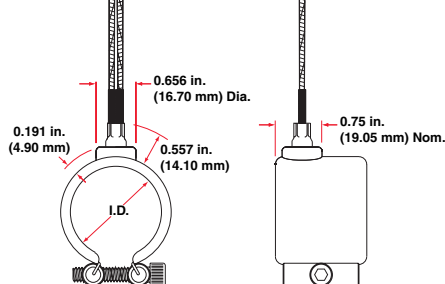

Type K: Flexible lead wires exit vertically from the heater. These leads can be bent adjacent to the heater for a quick and easy connection. To order, specify **Type K** and **length**.

### Type E

**Stock**

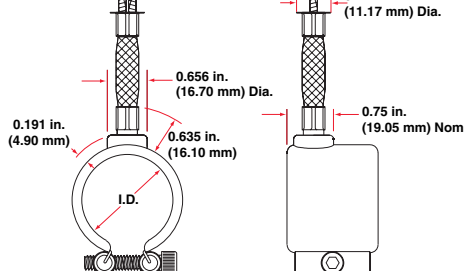

Type E: Loose metal braid encloses two fiberglass leads for good abrasion protection, lead flexibility and wiring convenience. Leads are two inches (51 mm) longer than braid. Shipped with 12 inch (305 mm) leads, unless longer length is specified. To order, specify **Type E** and **length**.

### Type F

**Stock**

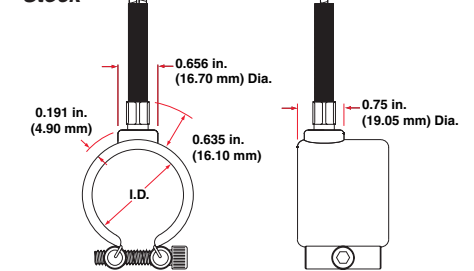

Type F: Loose fiberglass sleeving encloses two fiberglass leads for additional insulation protection where high temperature or minor abrasion is present. Leads are two inches (51 mm) longer than the sleeving. To order, specify **Type F** and **length**.

### Type H

**Stock**

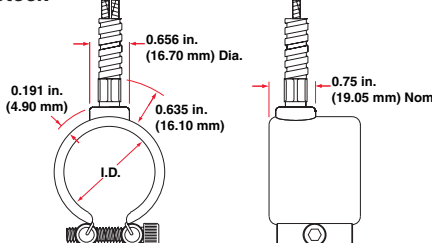

Type H: A flexible steel hose encloses the leads for maximum abrasion protection. Leads are two inches (51 mm) longer than hose. Shipped with 12 inch (305 mm) leads, unless longer length is specified. To order, specify **Type H** and **length**.

# Band Heaters

## MI Barrel and Nozzle Variations

### Lead Wire

Heaters rated at less than 250V~(ac) use UL® approved lead insulation for operations to 250°C (480°F) as standard. Lead insulation UL® rated for operation to 450°C (840°F) is available for high temperature applications where the leads are shrouded or enclosed with the heater. These leads are available in any of the Type B with loose braid, as well as Types E, F and H lead configurations. All heaters rated at more than 250V~(ac) use this wire. When ordering, specify **450°C (850°F) wire**.

### Ground Wire

Insulated ground wire is available, consult factory.

### Thermocouple

ASTM Type J or K thermocouples are available on lead Type B with loose braid. The thermocouple junction, spot-welded to heater sheath which provides a signal for measuring relative heater temperature. A separate thermocouple is available.

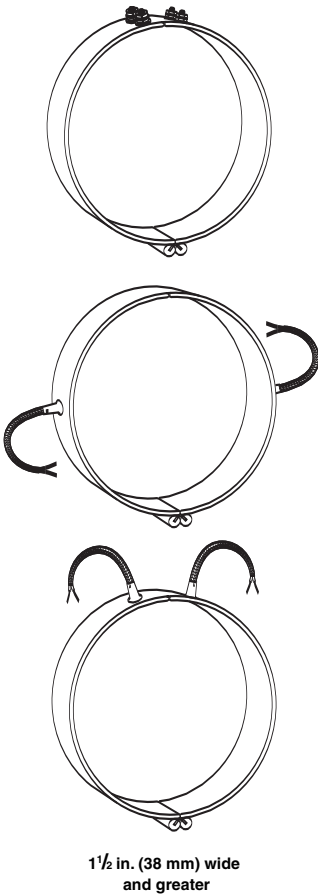
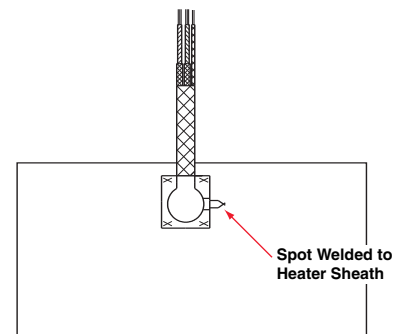

### Expandable Heaters With Post Terminals or Leads

Expandable heaters are two-piece units with a common top metal that allows the heater to expand open to the full diameter of the barrel. On expandable bands, each half will be one half of the total wattage. Plus, on both expandable and two-piece bands, each half will be rated at full operating voltage, unless otherwise specified.

**MI Band heaters 1 1/2 inches (38 mm) wide or greater** will have post terminals located next to the expansion joint. Leads may be located anywhere along the

circumference except near the gap and at the expansion joint. Two sets of leads required.

### On one inch (25 mm) wide

MI band heaters, post terminals will be located 90 degrees from the expansion joint. Leads may be located anywhere along the circumference except near the gap and at the expansion joint. Two sets of leads required. To order, specify **expandable**. Expandable heaters are designed to be opened for new installation only.

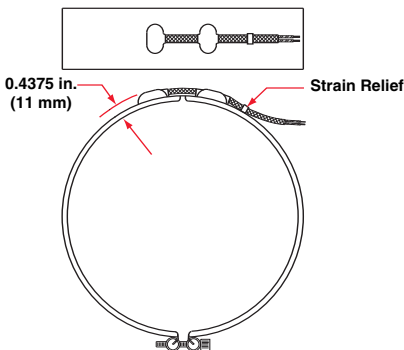

### Type SLE

Two fiberglass lead wires exit a single, tightly woven metal braid at right angle on the expandable construction versus two sets of leads. The minimum diameter

capability is four inches (100 mm). Minimum width capability is 1 1/2 inches (38 mm). To order, specify **Type SLE** and **length**.

UL® is a registered trademark of Underwriter's Laboratories, Inc.

# Band Heaters

## MI Barrel and Nozzle

### Variations

Continued

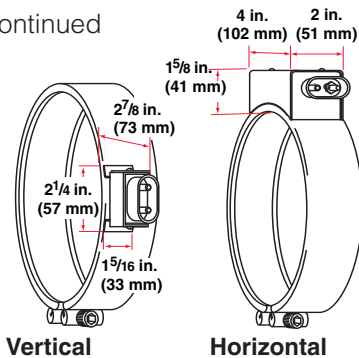

**Vertical**

**Horizontal**

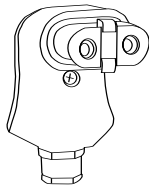

**Right Angle**

Code# N6027AF049

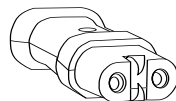

**Straight**

Code# N6027ZZ028

### High Temperature "Quick Disconnect" European Style Plugs

They provide the simplest and safest way to apply power to band heaters. The combination of high temperature male and female quick disconnect plug assemblies eliminates all live exposed terminals and electrical wiring that can be a

potential hazard to employees or machine. Maximum 15 amps at 240V~(ac), maximum 240 volts. To order, specify **vertical** or **horizontal** European plug.

### High Temperature "Quick Disconnect" European Style Female Adapters

Available as an accessory item that must be used in conjunction with high temperature "quick disconnect" European style plugs.

To order, specify code number **N2027AF049** or **N6027ZZ028** and quantity.

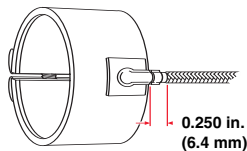

### Heavy Duty Strain Relief

Heavy duty strain relief is recommended for applications where there is great stress or continued flexing of the leads. The strain relief is available on

Type B, Type B—90 degree and Type B—180 degree leads only. To order, specify **heavy duty strain relief**. **Note:** not available with loose braid or fiberglass sleeving.

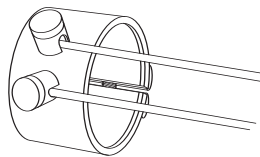

### Ceramic Terminal Cover

Ceramic covers, with openings for leads, are screwed on to post terminals, providing a convenient, economical insulator. To order,

specify code number **Z-4918** and **quantity**. Ceramic terminal covers are also available in metric, specify thread.

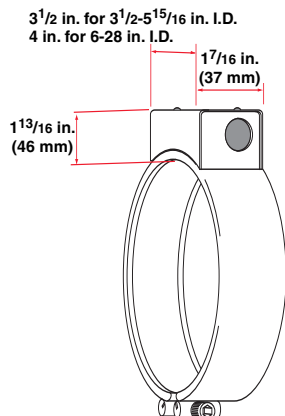

### Metallic Terminal Box

Metallic terminal boxes are available from stock on 3 1/2 inches inside diameter x 1 1/2 inches wide (89 mm x 38 mm) or larger heaters. Terminal boxes, which attach directly to the heater, act as a safety feature by covering the terminals. Conduit may be attached to the box through 7/8 inch (22 mm) diameter holes in the ends

of the box. Two-piece heaters require two boxes. To order, specify **terminal box**.

Oversized terminal boxes are available on heaters two inches (51 mm) and wider. Consult a Watlow representative for more information.

# Band Heaters

## MI Barrel and Nozzle

### Variations

Continued

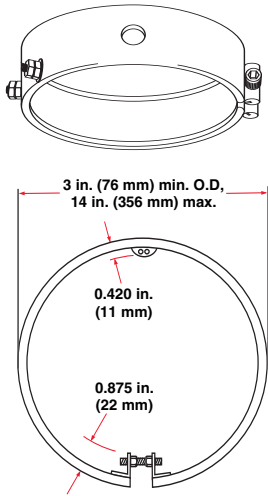

#### MI Band Heater With Holes

MI band heaters with holes are available on all widths except one inch wide. Consult the Watlow factory in St. Louis, Missouri for hole sizes and location restraints. To

order, specify **hole size** and **location**. There is a three inch inside diameter minimum. See technical letter "MI Band #2" for location.

#### Outside Diameter Heater

Two fiberglass insulated lead wires rated to 450°C (840°F) exit a metal braid 180 degrees opposite from gap, Type B outside diameter

designed and constructed to mate with inside diameter of cylinders. To order, specify **outside diameter and width** of heater.

### Clamping Variations

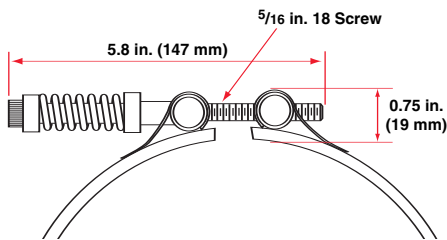

#### Tig Welded Barrel Nuts with Spring Loaded Clamping

Welded barrel nuts with spring loaded clamping are used during start-up to maintain a tight heater fit on large barrels. This clamping variation is standard for all MI band heaters that are greater than 14 inches (355 mm) in diameter and

1½ inches (38 mm) or greater in width. Refer to *MI Band Clamping Matrix Application Guide*. For smaller diameter heaters, it is an option and must be ordered separately. To order, specify **spring loaded clamping**.

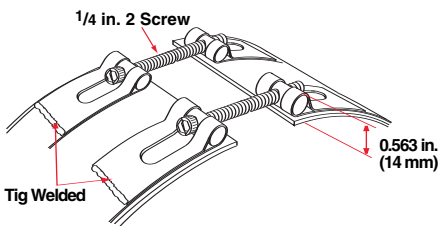

#### Tig Welded Barrel Nuts

An ideal way to provide access for instrumentation is to specify an oversized gap between the heater ends. If the clamp bar screw interferes with the positioning of

the instrumentation device, welded barrel nuts are recommended. To order, specify **tig welded barrel nuts** and **gap dimension** when ordering.

#### Low Profile Tig Welded Barrel Nuts

Low profile barrel nuts are available on all widths. Low profile barrel nuts have a clearance of 0.406 inch

(10 mm). To order, specify **low profile tig welded barrel nuts**.

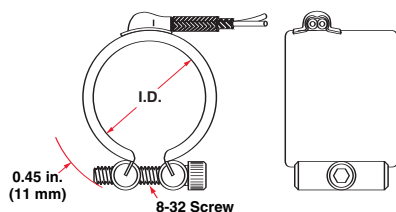

#### Low Profile Clamp Bars

Low profile clamp bars are available on both one (25 mm) and 1½ inch (38 mm) wide heaters, for wider widths consult factory. The bars are

¼ inch (6 mm) diameter with an 8-32 screw. To order, specify **low profile clamp bars**.

# Band Heaters

## MI Barrel and Nozzle

### MI Stock Product

F.O.B.: St. Louis, Missouri

I.D. in. (mm)	Width in. (mm)	Construction	Volts	Watts	Watt Density		Termination	Approx. Net. Wt.		Avail.	Code No.
					W/in <sup>2</sup>	(W/cm <sup>2</sup> )		lbs	(kg)		
1 (25.4)	1 (25.4)	1 pc	120	150	92	(14.2)	Type B,C,E, F or H	0.1	(0.05)	Stock	MB1A1AN1
	1 (25.4)	1 pc	120	100	61	(9.4)	Type B,C,E, F or H	0.1	(0.05)	Stock	MB1A1AN2
	1 (25.4)	1 pc	120	200	122	(18.9)	Type B,C,E, F or H	0.1	(0.05)	Stock	MB1A1AN3
	1 (25.4)	1 pc	240	200	122	(18.9)	Type B,C,E, F or H	0.1	(0.05)	Stock	MB1A1AN4
	1½ (38.1)	1 pc	240	300	106	(16.4)	Type B,C,E, F or H	0.1	(0.05)	Stock	MB1A1JN1
	1½ (38.1)	1 pc	120	300	106	(16.4)	Type B,C,E, F or H	0.1	(0.05)	Stock	MB1A1JN2
	1½ (38.1)	1 pc	240	200	70	(10.8)	Type B,C,E, F or H	0.1	(0.05)	Stock	MB1A1JN3
1¼ (31.8)	1 (25.4)	1 pc	240	250	104	(16.1)	Type B,C,E, F or H	0.1	(0.05)	Stock	MB1E1AN1
	1 (25.4)	1 pc	120	250	104	(16.1)	Type B,C,E, F or H	0.1	(0.05)	Stock	MB1E1AN2
	1 (25.4)	1 pc	240	300	124	(19.2)	Type B,C,E, F or H	0.1	(0.05)	Stock	MB1E1AN3
	1½ (38.1)	1 pc	240	350	87	(13.5)	Type B,C,E, F or H	0.2	(0.09)	Stock	MB1E1JN1
	1½ (38.1)	1 pc	120	350	87	(13.5)	Type B,C,E, F or H	0.2	(0.09)	Stock	MB1E1JN2
	1½ (38.1)	1 pc	240	450	112	(17.3)	Type B,C,E, F or H	0.2	(0.09)	Stock	MB1E1JN3
1½ (38.1)	1 (25.4)	1 pc	240	300	93	(14.4)	Type B,C,E, F or H	0.1	(0.05)	Stock	MB1J1AN1
	1 (25.4)	1 pc	120	300	93	(14.4)	Type B,C,E, F or H	0.1	(0.05)	Stock	MB1J1AN2
	1 (25.4)	1 pc	240	200	62	(9.6)	Type B,C,E, F or H	0.1	(0.05)	Stock	MB1J1AN3
	1 (25.4)	1 pc	240	400	125	(19.3)	Type B,C,E, F or H	0.1	(0.05)	Stock	MB1J1AN5
	1½ (38.1)	1 pc	120	300	58	(9.0)	Type B,C,E, F or H	0.2	(0.09)	Stock	MB1J1JN1
	1½ (38.1)	1 pc	240	450	87	(13.5)	Type B,C,E, F or H	0.2	(0.09)	Stock	MB1J1JN2
	1½ (38.1)	1 pc	240	300	58	(9.0)	Type B,C,E, F or H	0.2	(0.09)	Stock	MB1J1JN3
	1½ (38.1)	1 pc	240	600	116	(17.9)	Type B,C,E, F or H	0.2	(0.09)	Stock	MB1J1JN4
	1½ (38.1)	1 pc	240	450	96	(14.8)	Post	0.2	(0.09)	Stock	MB1J1JP6
	2 (50.8)	1 pc	240	450	57	(8.8)	Type B,C,E, F or H	0.3	(0.14)	Stock	MB1J2AN1
	2 (50.8)	1 pc	240	300	42	(6.5)	Type B,C,E, F or H	0.3	(0.14)	Stock	MB1J2AN2
	2 (50.8)	1 pc	240	900	125	(19.3)	Type B,C,E, F or H	0.3	(0.14)	Stock	MB1J2AN3
	3 (76.2)	1 pc	240	500	45	(7.0)	Type B,C,E, F or H	0.4	(0.18)	Stock	MB1J3AN1
	3 (76.2)	1 pc	240	350	31	(4.8)	Type B,C,E, F or H	0.4	(0.18)	Stock	MB1J3AN2
1¾ (44.5)	1¾ (34.9)	1 pc	240	450	83	(12.8)	36° 90° B type braid w/HD strain relief	0.2	(0.09)	Stock	MB1N1GX3A
	1½ (38.1)	1 pc	240	300	47	(7.3)	Type B,C,E, F or H	0.2	(0.09)	Stock	MB1N1JN1
	1½ (38.1)	1 pc	120	300	50	(7.7)	Type B,C,E, F or H	0.2	(0.09)	Stock	MB1N1JN2
	1½ (38.1)	1 pc	240	700	110	(17.0)	Type B,C,E, F or H	0.2	(0.09)	Stock	MB1N1JN3
	2 (50.8)	1 pc	240	750	86	(13.3)	Type B,C,E, F or H	0.3	(0.14)	Stock	MB1N2AN1
	2 (50.8)	1 pc	240	350	73	(11.3)	Type B,C,E, F or H	0.2	(0.09)	Stock	MB2A1AN1
2 (50.8)	1 (25.4)	1 pc	120	350	73	(11.3)	Type B,C,E, F or H	0.2	(0.09)	Stock	MB2A1AN2
	1 (25.4)	1 pc	240	450	94	(14.5)	Type B,C,E, F or H	0.2	(0.09)	Stock	MB2A1AN3
	1 (25.4)	1 pc	240	350	79	(12.2)	36° 90° B type braid w/HD strain relief	0.2	(0.09)	Stock	MB2A1AX6B
	1½ (38.1)	1 pc	240	400	53	(8.2)	Type B,C,E, F or H	0.3	(0.14)	Stock	MB2A1JN1
	2 (50.8)	1 pc	240	750	73	(11.3)	Type B,C,E, F or H	0.4	(0.18)	Stock	MB2A2AN1
	2 (50.8)	1 pc	240	1200	125	(19.3)	Type B,C,E, F or H	0.4	(0.18)	Stock	MB2A2AN2
	2 (50.8)	1 pc	240	750	75	(11.6)	36° 90° B type braid w/HD strain relief	0.2	(0.09)	Stock	MB2A2AX2A
	2 (50.8)	1 pc	240	750	63	(9.7)	120° 180° B type braid w/HD strain relief	0.2	(0.09)	Stock	MB2E2AX7
2½ (63.5)	2½ (63.5)	1 pc	240	1000	72	(11.2)	Type B,C,E, F or H	0.5	(0.23)	Stock	MB2E2JN1
	1 (25.4)	1 pc	240	400	63	(9.7)	Type B,C,E, F or H	0.2	(0.09)	Stock	MB2J1AN1
	1½ (38.1)	1 pc	240	500	50	(7.7)	Type B,C,E, F or H	0.4	(0.18)	Stock	MB2J1JN1

Band Heaters

CONTINUED

## MI Barrel and Nozzle

### MI Stock Product (con't)

I.D. in. (mm)	Width in. (mm)	Construction	Volts	Watts	Watt Density W/in <sup>2</sup> (W/cm <sup>2</sup> )	Termination	Approx. Net. Wt. lbs (kg)	Avail.	Code No.
3 (76.2)	1 (25.4)	1 pc	240	400	54 (8.4)	Post	0.3 (0.14)	Stock	MB3A1AP1
	1½ (38.1)	1 pc	240	500	40 (6.2)	Post	0.4 (0.18)	Stock	MB3A1JP1
	1½ (38.1)	2 pc exp	230/460	525	53 (8.2)	Post	0.4 (0.18)	Stock	ME3A1JP10
3½ (88.9)	2 (50.8)	1 pc	240	800	42 (6.5)	Post	0.7 (0.32)	Stock	MB3J2AP2
3¾ (92.1)	1½ (38.1)	2 pc exp	230/460	650	51 (7.9)	Post	0.5 (0.23)	Stock	ME3L1JP5
4 (101.6)	1 (25.4)	1 pc	240	700	62 (9.6)	Post	0.4 (0.18)	Stock	MB4A1AP1
	1½ (38.1)	1 pc	240	800	48 (7.4)	Post	0.6 (0.27)	Stock	MB4A1JP2
	1½ (38.1)	2 pc exp	230/460	625	43 (6.6)	Post	0.6 (0.27)	Stock	ME4A1JP11
	1½ (38.1)	2 pc exp	230/460	725	50 (7.8)	Post	0.6 (0.27)	Stock	ME4A1JP12
4½ (114.3)	2½ (63.5)	1 pc	240	1250	40 (6.2)	Post	1.0 (0.45)	Stock	MB4J2JP1
5 (127.0)	1½ (38.1)	2 pc exp	240/480	1000	52 (8.1)	Post	0.8 (0.36)	Stock	ME5A1JP8
5½ (133.4)	1½ (38.1)	2 pc exp	230/460	600	29 (4.5)	Post	0.7 (0.32)	Stock	ME5E1JP9
	3 (76.2)	2 pc exp	230/460	1700	40 (6.2)	Post	1.5 (0.68)	Stock	ME5E3AP5
	4½ (114.3)	2 pc exp	230/460	2400	38 (5.9)	Post	2.2 (1.0)	Stock	ME5E4JP2
5½ (139.7)	1½ (38.1)	2 pc exp	240/480	1000	46 (7.1)	Post	0.9 (0.40)	Stock	ME5J1JP1
6 (152.4)	1½ (38.1)	2 pc exp	240/480	1000	41 (6.4)	Post	0.9 (0.40)	Stock	ME6A1JP2
6½ (165.1)	1½ (38.1)	2 pc exp	240/480	1250	47 (7.3)	Post	1.0 (0.45)	Stock	ME6J1JP5
6¾ (171.5)	4 (101.6)	2 pc exp	230/460	2600	35 (5.4)	Post	2.5 (1.1)	Stock	ME6N4AP2
7½ (190.5)	1½ (38.1)	2 pc exp	240/480	1500	47 (7.3)	Post	1.1 (0.50)	Stock	ME7J1JP4
8 (203.2)	1½ (38.1)	2 pc exp	240/480	1250	37 (5.7)	Post	1.2 (0.54)	Stock	ME8A1JP4
9 (228.6)	1½ (38.1)	2 pc exp	240/480	1500	39 (6.0)	Post	1.4 (0.64)	Stock	ME9A1JP1
9½ (241.3)	3 (76.2)	2 pc exp	230/460	3000	37 (5.7)	Post	2.6 (1.2)	Stock	ME9J3AP2
11¼ (285.8)	5 (127.0)	2 pc exp	230/460	5100	31 (4.8)	Post	5.2 (2.4)	Stock	ME11E5AP1

#### How to Order

To order your stock MI band heater, specify:

- Quantity
- Watlow code number
- Options
- Lead type and length, or terminal type configuration (If code number has an "N" as the last letter in the code, you must specify termination type and lead length. The leads supplied are twelve inches if not otherwise specified.)
- Right angle leads not available on leadless stock ("N").

#### Availability

**Stock:** Same day shipment on MI Band heaters with post terminals or 12 inch (305 mm) Type B leads. Longer lead lengths or other terminations will ship next day. 90 degree Type B leads are not available from stock.

**Made-to-Order:** If stock units do not meet application needs, Watlow can manufacture MI Band heaters to special requirements. Please consult a Watlow sales engineer or authorized distributor.